

Product Specification

PD-8X

Item

Specification

NOTE : Hub Serial No. : 8XA1 , Font size : 1.4 mm.
99999 ,
 Product Code
 Serial No.

Laser etching way: Both sides with different patterns, which should follow the drawing.

Axle Fixing Bolt	QR
Spoke Hole	32 / 36
Seal	Bearing *2
Output Volage	6V3W
Wheel Diameter	646~716mm
Weight	465g
Dynamo	MD003

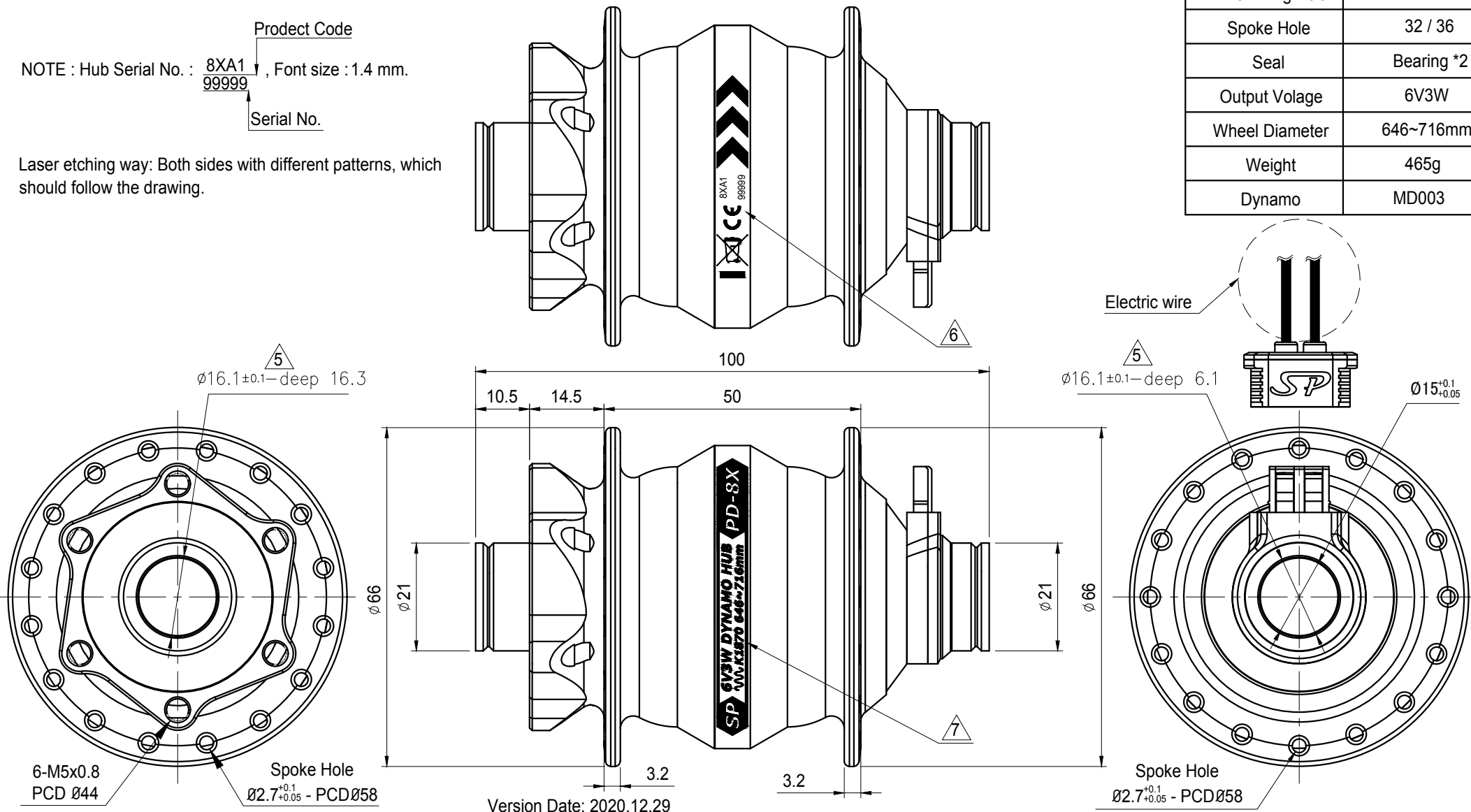

Version Date: 2020.12.29

7	2020.12.29		Laser etching way is change	UNIT:mm	SCALE	TOLERANCE
6	2020.07.21		Laser etching way is change		1:1	± 0.5
5	2017.05.12		Dimensions marked			
4	2016.11.28		Modification of disc brake mechanism shape and part design	MAKE	CHECK	CONFORM
△	Version Date	ECR No.	Description			

Hub dynamo	
MODEL	
PD-8X-07	